

# **The Villages at Wicklow**

## **Phase III - Design Guidelines**

### ***General Building Design Standards*** ***Updated on 7.13.15***

#### **Overview and Intent**

Design Guidelines are a means to preserve the individuality, quality, integrity and enduring value expected by every homeowner within a community.

The Villages at Wicklow Design Guidelines provide a design “theme” for every home. They are written to inspire innovative and creative home designs, but are not intended to be used as a restrictive set of rules. These Design Guidelines will remain flexible over time, creating the opportunity to respond to market trends, buyer tastes, property owners’ association needs, and economic market cycles.

The Guidelines are a framework that provides the homeowner with a method of directing their builders and designers, while maintaining consistent quality design throughout the neighborhood. In addition, the Villages at Wicklow landscape standards become the theme that visually unites the community and its evolving character.

#### **Community Planning of The Villages at Wicklow**

The goal of the Villages design team is to establish a community that is sensitively integrated into the natural beauty of the development. The team hopes to achieve this goal by developing a land plan that embraces a balance of land uses. The community of The Villages at Wicklow is the weaving together of the neighborhoods into the fabric of natural landscape. The open personality of the community is continually reinforced as property owners are surrounded by the natural environment.

#### **Basic Guidelines**

The Villages at Wicklow Design Review Board (VWDRB) requires drawings that can be easily understood. All designs must reflect traditional architecture. The VWDRB will consider all designs on an individual basis. Plans which are not designed by licensed architects or home designers will not be reviewed by the Design Review Board. The VWDRB will have full approval authority over all construction plans and their ruling will be final. By way of illustration, but without limitation, the following improvements require submission to the VWDRB for approval:

- New construction or exterior additions/modifications of any kind.
- Installation or modification of landscaping.
- Changes or other improvements subsequent to original approvals.

Approval of any project by the VWDRB does not waive the requirement for permits from the City of Nixa, Christian County, State of Missouri, or any other governmental agency having jurisdiction in The Villages at Wicklow.

### **Size of Residence**

It is expected that the size of the home will maximize the footprint of the lot and will be comparable to existing home sizes.

### **Setbacks**

Residences shall adhere to minimum setback requirements established by governmental regulations and as shown on the final plat.

**NOTE:** Building envelopes will vary depending on actual lot size. Refer to Final Plat Map and your individual home site plot for lot setbacks that exceed those indicated above.

### **Garages and Parking Spaces**

Each residence shall contain parking space within the site for at least two automobiles in a private, fully enclosed garage with functional doors. The interior walls of any garage must be like other rooms of the building. No carports will be allowed. No more than two garage doors may exist on the same plane. The minimum offset on third or fourth garage doors is three feet. Integrated garages should be visually removed to reduce the impact to the street scene. The garage door design should be representative of the home design.

### **Driveways**

All driveways shall be constructed of either concrete or other equivalent material as approved by the VWDRB. Property owners shall be responsible for extending their driveway to the edge of the street pavement. All curb cuts and subsequent repairs, due to driveway connection to the street, are the responsibility of the property owner. The driveway must be extended to the street's edge once the street is paved.

### **Walks**

Sidewalk minimum width is four feet, constructed of concrete or other equivalent material approved by the VWDRB. Vertical, exposed concrete steps are not allowed. Sidewalks must meet City code (see attachments).

### **Exterior Walls**

Exterior walls must be substantially brick, stone, stucco, (synthetic stucco i.e. Dryvit not allowed). Wood may also be used in a well-chosen combination of either brick, stone, stucco, or as an accent material. A combination of no more than three different materials may be used. The front elevation shall be at least 75% brick, stone, or stucco, and the remaining 25% shall be any other material except vinyl siding such as cedar siding,

masonry board and batten. The 75/25 shall continue on the remaining three sides of the home if the lot has a public view. An example of a public view would be a lake lot or corner lot. If the lot does not have a public view (per Design & Review Board), then it will be left for the builder to decide the exterior of the remaining three sides of the home. We understand that certain architectural styles may not correspond with this rule and will review those situations on an individual basis. The VWDRB reserves the right to deny approval of any exterior plans.

No vinyl siding of any kind will be permitted.

Color combinations must be submitted for approval by the VWDRB.

The main entry should contain more detail than the other openings but remain consistent in styling.

Masonry or stone facing used in combination as a veneer material on the front of the residence should return around a corner to a logical point of termination such as an inside corner.

Gutters and downspouts shall be used at all eave lines unless deemed inappropriate and should be either colored aluminum or copper material. Galvanized material is not permitted.

Exterior window and door details are encouraged.

Casement windows with grilles to be used on all front elevations.

Retaining walls shall be constructed of a natural type material, or products that conform to the home. Block or diamond block is not permitted. Retaining walls that attach to the residence should utilize the same materials as the wall that they join.

### **Drainage**

A proper drainage plan for individual home sites is an important part of the overall plan for the community. Water runoff from each individual building site must be handled by adequately sloping all areas so that runoff is directed to the natural drainage areas or storm drainage facilities of each lot owner. A drainage plan must be incorporated when the site plan is submitted for approval. Directional arrows may be used on the site plan to illustrate drainage plan.

Temporary and permanent erosion control measures are intended to prevent the erosion of soil at The Villages of Wicklow. The placement of barriers such as erosion fabric fences, straw bales, or curb-like diversions along the perimeter of construction areas is considered a temporary measure to prevent excessive run-off.

Run-off from construction areas must be directed away from any sensitive natural areas. Permanent measures include the use of plant material to hold soil in place and the proper grading of the site. Drainage facilities shall use the natural systems wherever possible. Previous surfaces rather than hard surfaces are encouraged to promote ground percolation.

### **Decks**

Decks and their supports should be of materials that relate to the residence. Support columns must be 6" X 6" minimum. The deck railing design should reflect creative detail.

### **Roof**

Roof pitches to be a minimum of a 10/12 and will be inspected to ensure proper roof pitch is constructed. A minimum of 30 year architectural shingles are required.

### **Patios**

Patios should reflect creative design and detail. The floor (walking surface) should use materials that relate to the residence.

### **Outside Equipment**

All boats and recreational vehicles must be kept in a garage or other structure designed in keeping with the architecture of the residence. The VWDRB must approve the locations of all recreation equipment, playground sets or yard structures before installation. Yard structures of any type (i.e.; statues, furniture) are not permitted in the front or side yards

### **Landscaping Criteria**

The following residential landscape design criteria are provided to enhance the definition of each homesite. The primary goal is to protect and maximize individual property values through the implementation of a minimal but generous landscape treatment. This criteria must be followed to successfully receive the approvals required by the VWDRB.

*\*\*The typical home uses 10% of their total budget for landscaping\*\**

#### **It is required to use one of the following landscape companies:**

Natures Image – 417-724-8774

Elite Irrigation – 417-885-9898

James River Lawncare – 417- 725-5819

Sod is required in all areas.

No trees 8" or over in caliper size can be removed within 25' of the boundary of any common areas without the permission of the Design Review Board.

Rear yards of homes adjacent to any open common areas require landscape treatment similar with that of the front yard.

All grassed areas shall be provided with underground irrigation systems.

Should a significant number of existing site trees be able to be retained, and thrive after construction, the requirement for additional tree plantings may be waived. The VWDRB will determine which trees will be considered significant and retained.

***Trees Requirements:***

Front yard (and side yards on corner lots):

- Shade trees 2" minimum caliper, 8' tall, 1 per 1000 square feet
- 1 ornamental accent tree at least 1-1/2" minimum caliper

Rear yard:

- Shade trees 2" minimum caliper, 8' tall, 1 per 2000 square feet
- 1 ornamental accent tree at least 1-1/2" minimum caliper

*All areas are based on irrigated areas only*

Lots that do not back up to property that is a part of The Villages at Wicklow will be reviewed by the VWDRB on an individual basis.

The following shade/street and ornamental trees may be used pending approval from the VWDRB:

Bald Cypress	White Spire Birch	Japanese Maple
Shademaster Honeylocust	Tulip Poplar	White Bud
London Plane Tree	Norway Maple	Star Magnolia
Aristocrat Pear	Red Maple	Northway Spruce
Caddo Sugar Maple	Easter Redbud	White Oak
Northern Red Oak	Flowering Dogwood	Scarlet Oak
English Oak	Amur Maple	Shumard Oak
Chanticleer Pear	Keteleeri Juniper	Canadian Hemlock
White Pine	Flowering Crabapple	Willow Oak
Saw Tooth Oak	Serviceberry	River Birch
Bur Oak	Ash	Pin Oak
Sweetgum	Russian Olive	Smoke Tree
Foster Holly	Purple-Leaf Plum	Cornelian Cherry

**Please note:** Bradford Pear trees are not permitted. Additional tree species will be considered by the Board upon request.

**Planting Beds:**

- Landscape beds should make up 10% of front yards.
- You must hide all HVAC units and Electrical boxes with landscaping
- The VWDRB will make determination regarding corner lot landscaping on an individual basis.
- Perennials must be a minimum of 1 Gallon, all others must be a minimum of 3 Gallons
- Landscape beds must be full based on maturity

**Please note:** Lots which are back-to-back within the development shall require a minimum of 3% of rear yard to be covered with landscaping beds, and those that back up to public views or open common areas shall require a minimum of 10%. Lots that do not back up to Wicklow property will be reviewed by the VWDRB on an individual basis.

The following shrub specimens are appropriate in the Villages at Wicklow community:

Potentilla	Andorra Juniper	Mint Julep Juniper
Compact Amur Maple	Rose of Sharon/Althea	Densiformis Yew
Common Lilac	Redtwig Dogwood	Anthony Waterer Spirea
Cistena Plum	Forsythia	Little Princess Spirea
Gold Tip Juniper	Old Gold Juniper	Blue Mist Spirea
Capitata Yew	Nana Procumber	Redleaf Barberry
China Girl Holly	Hicks Yew	Blue Pacific Juniper
Mentor Barberry	Dwarf Korean Lilac	Hydrangia
Purpleleaf Smoketree	Golden Barberry	Crape Myrtle
Persian Lilac	Snowmound Spirea	Blue Princess Holly
Emerald Cushion Euonymus	Boxwood	Crimson Pygmy Barberry
Pink Flowering Almond	Pussy Willow	Girard Azalea
Emerald Isle Juniper	Japanese Flowering Quince	Emerald Gaiety Euonymus
Sarcoxie Euonymus	Lodense Privet	Glossy Abelia
Compact Burning Bush	Dwarf Burford Holly	PJM Rhododendron
Bar Harbor Juniper	Vanhoutte Spirea	

**Please note:** Additional species will be considered by the Board upon request.

Landscape bedding ground covers should be a natural-like cover of mulch, decorative gravel, etc. Materials such as Lava Rock, white rock, masonry block, or diamond landscape blocks are considered inappropriate for the Villages at Wicklow community.

***Retaining Walls:***

In some instances, it may be necessary to provide retaining structures to protect trees near roadways and other graded areas. Such retaining structures should have a natural appearance, using natural materials such as stone, wood ties, etc.

***Surface Drainage:***

The surface drainage system shall consist primarily of on-grade pervious systems. Hardscape materials are permitted when no other options are available. The use of underground storm drains should be minimized. Drainage of individual properties must work with the existing topography, and be directed toward the natural open space or drainage swale systems, developed in conjunction with the roadways. Community landscape areas and amenities must be protected during all construction operations through the use of fencing or other barriers. Adequate provision must be made to prevent any surface waters from damaging public or private property, or excavation areas and fill slopes, both during and after construction.

**Fences**

Interior lots of the subdivision shall not have any fence wood or iron higher than 4' tall. All remaining lots will be submitted to Design & Review Board for approval if higher than 4' is requested. Fences to be built in a "shadow box" or "good neighbor" design if constructed of wood. No chain link allowed. City permits are required on all fences.

Lots backing up to a collector road (Old Castle or Tracker) will have a 5' fence provided by the developer on the rear or side property line running along the side of the road. This will be a Copperwood fence and shall be maintained by the property owner once the lot is sold. The fence shall not be stained a color on the side of the fence backing up to the collector road. Iron fence will not be allowed on the side backing up to the collector road to maintain consistency along these streets.

**Mailboxes**

All mailboxes must match existing copper mailboxes in The Villages at Wicklow. The Villages at Wicklow will provide and install these mailboxes. The fee is \$450 per mailbox and must be paid at time of closing on the lot.

**Swimming and Spa Pools**

No above ground swimming pools are allowed. All in-ground swimming pools must be designed and engineered in compliance with applicable codes. Swimming pools should be visually connected to the residence through walls or courtyards and screened or separated from strict view of the street, or of neighboring properties. Backwash water, from swimming pools and spas, is not permitted to be discharged into any part of the sewer system, wash over or erode adjoining property.

**Tennis Courts**

Tennis courts are not allowed.

**Underground Wiring**

All exterior wiring shall be installed underground. Electric transformer, phone and cable TV pedestals should be landscaped in a manner to shield such facilities from view.

-----  
**Builders please note: A portable lavatory is required every 100 to 150 feet on building sites. You are required to keep and maintain at least one at all times. If you are sharing a portable lavatory with another builder, please specify the name of the builder on your Design Review Application.**

**DESIGN REVIEW APPLICATIONS ARE NOT ACCEPTED PRIOR TO HAVING A CONTRACT ON A LOT**

*Please note that the Guidelines are provided to summarize the general building standards of The Villages at Wicklow community. It is highly recommended that you obtain a copy of The Villages at Wicklow Declaration of Restrictions and Covenants for additional rules and regulations.*

I/we have read the current The Villages at Wicklow Design Guidelines, Covenants, Conditions and Restrictions and fully understand the requirements set forth as they pertain to this application. All work will be completed in conformance with the approved documents and application. Any change to any building associated with this application shall be resubmitted to the Design Review Board and approval obtained prior to commencement of any and all improvements. During construction, I/we agree and will provide gravel to the driveway of this property for use as a temporary access.

Signature: \_\_\_\_\_ Date: \_\_\_\_\_





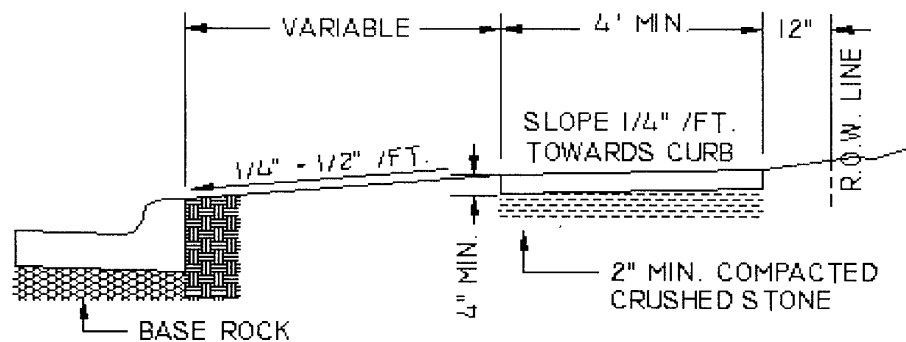

NOTES:

1. JOINTS SHALL BE FORMED AT RIGHT ANGLES TO THE ALIGNMENT OF THE SIDEWALK.
2. THE SIDEWALK SHALL BE MARKED OFF INTO SQUARE STONES BY CONTRACTION JOINTS. CONTRACTION JOINTS SHALL BE ONE-EIGHT (1/8) INCH WIDE (MIN.) BY ONE (1) INCH DEEP AND SHALL BE FORMED BY TOOLING.
3. EXPANSION JOINTS SHALL BE FORMED BY A ONE-HALF (1/2) INCH THICK PREFORMED JOINT FILLER, EXTENDING THE FULL DEPTH OF THE SLAB, AND SECURED SO THAT THE JOINT FILLER IS NOT MOVED BY DEPOSITING AND COMPACTING THE CONCRETE AT THESE JOINTS.
4. EXPANSION JOINTS SHALL BE PLACED WHERE SIDEWALK ABUTS TO OTHER STRUCTURES AND SHALL NOT BE SPACED MORE THAN 50 FEET APART ON STRAIGHT RUNS FOR HAND LAID SIDEWALK AND NOT MORE THAN 100 FEET APART ON STRAIGHT RUNS FOR MACHINE LAID SIDEWALKS.



CONCRETE SIDEWALK  
DETAIL

DATE:  
01/31/99

DWG:  
D3

# **The Villages at Wicklow**

## **Architectural Design Review Submittal and Approval Process**

7/13/15

**The Design Review Board meets the first Wednesday of every month or as needed.**

*Please allow 14 days for submittal review and processing.*

### **Application and Design Review Process**

- Two complete sets of plans professionally drawn by an architect must be submitted along with the Design Review Application to the *Development Office* located at The Village of Wicklow general office at 5051 S. National Suite 7B, Springfield, MO 65810. See checklist on page 4 for details of what must be included in the plans.
- The Liquidated Damages Deposit of \$1,000.00 must be submitted along with the application.
- CC Land Partners, LLC will determine if the submittal is complete and ready to be presented to the Board. Please note that incomplete applications will not be submitted.
- The Villages at Wicklow Design Review Board (VWDRB) approves or disapproves plans and will send comments to the owner and/or builder to proceed with construction or to resubmit the application after meeting the stated requirements.
- A Prior to Construction Property Verification and Inspection Form and certificates of insurance must be turned in to the Development Office before beginning construction.
- Upon completion of the review and approval process, the set of plans will be retained by VWDRB.
- A Builder Profile form must be completed & submitted to VWDRB.

### **Construction Completion**

- Upon completion of all improvements to the property, including all landscaping, the owner and/or builder shall submit the Improvements Completed Property Verification and Inspection Form to the Development Office, stating that improvements are complete and in conformance with the approved plans and specifications of the VWDRB. *This form must be submitted no later than one month after occupancy of the residence.*
- VWDRB will have 15 days to inspect property and improvements.
- After inspection, the VWDRB will notify the owner of either final approval or noncompliance.
- The Liquidated Damages Deposit, or any remaining portion, will be refunded at the time of final approval by the Design Review Board.

**The Villages at Wicklow**  
**Property Verification and Inspection -- Prior to Construction**

**Property Owner's Name:** \_\_\_\_\_

**Current Mailing Address:** \_\_\_\_\_

**Telephone Numbers:** Business/Day (\_\_\_\_) \_\_\_\_\_

Residence/Evening (\_\_\_\_) \_\_\_\_\_

Mobile (\_\_\_\_) \_\_\_\_\_

Homesite number of proposed construction: \_\_\_\_\_ **Phase:** \_\_\_\_\_

Homesite Address: \_\_\_\_\_

I/we have read the current The Villages at Wicklow Design Guidelines, Covenants, Conditions and Restrictions and fully understand the requirements set forth as they pertain to property damage. I/we have physically inspected the above home site and features listed below prior to commencement of construction and do hereby verify that **NO** damage has been found to lot or adjacent lots. I/we understand that if damage occurs to a feature listed below as a result of construction, it is my/our responsibility to repair or replace such damaged feature, and that the liquidated damage deposit placed with The Villages at Wicklow will be held until such repair(s) are complete. I/we understand that an inspection will be done again after completion of home and landscaping.

**Property Verification – Indicate Condition of the Following Existing Elements:**

A. Pins are Located (Property Boundary Lines)

B. Damage to Property/Amenities

1. Sidewalk/Curbs (if applicable)

2. Community Fencing

3. Debris on lot or any adjacent lots

Signature: \_\_\_\_\_ Date: \_\_\_\_\_

Comments: \_\_\_\_\_

*For the use of The Villages at Wicklow Design Review Board only*

Homesite Number: \_\_\_\_\_

Date Received: \_\_\_\_\_

Received By: \_\_\_\_\_

**The Villages at Wicklow**  
**Design Review Application**

**Ownership Data**

Property Owner's Name: \_\_\_\_\_

Current Mailing Address: \_\_\_\_\_

Telephone Numbers: Business/Day ( ) \_\_\_\_\_

Residence/Evening ( ) \_\_\_\_\_

Mobile ( ) \_\_\_\_\_

Homesite number of proposed construction: \_\_\_\_\_ Phase: \_\_\_\_\_

Homesite Address: \_\_\_\_\_

**Architect/Designer Data**

Architect/Designer's Name: \_\_\_\_\_

Company Name: \_\_\_\_\_

Mailing Address: \_\_\_\_\_

Telephone Numbers: Business/Day ( ) \_\_\_\_\_

Residence/Evening ( ) \_\_\_\_\_

Mobile ( ) \_\_\_\_\_

**Contractor/Builder Data**

Contractor/Builder Name: \_\_\_\_\_

Company Name: \_\_\_\_\_

Mailing Address: \_\_\_\_\_

Telephone Numbers: Business/Day ( ) \_\_\_\_\_

Residence/Evening ( ) \_\_\_\_\_

Mobile ( ) \_\_\_\_\_

**Home Details and Areas**

Architectural Style: \_\_\_\_\_

Covered Deck/Porch Area S.F.: \_\_\_\_\_

Uncovered Deck/Porch Area S.F.: \_\_\_\_\_

Patio Area S.F.: \_\_\_\_\_

**PLEASE USE THE FOLLOWING CHECK LIST TO ENSURE ALL NECESSARY INFORMATION IS INCLUDED WITH YOUR SUBMITTAL**

**Plan Submittal – 2 complete sets**

- A. Construction Plans
  - 1. Square Footage per Level
    - a. Basement
    - b. Main
    - c. Upper
  - 2. Garage Square Footage
    - a. Two-Car
    - b. Three-Car
  - 3. Elevations must have all exterior products drawn in (see pg. 8) and include:
    - a. Front
    - b. Side
    - c. Rear
    - d. Entry/Porch including Front Step Details
    - e. Deck/Patio/Post/Railing Details
    - f. Garage Door Design Details
    - g. Window Grids, if used
  - 4. Roof Elevations (plans must include the following)
    - a. Roof Pitch
    - b. Dormer Pitch
    - c. Fireplace Flue – Elevations, Size, Materials

Note: *No skylight or vents are allowed on front elevation.*
- B. Site Plan (must include the following at appropriate scale size of 1"=20)
  - 1. Building Envelope
  - 2. Building Setbacks
  - 3. Existing and Proposed Grading Contours outlining drainage plan ensuring water runoff to appropriate natural drainage areas
  - 4. Finished Floor Elevation
  - 5. Hay Bale or Silt Fencing Location
  - 6. Accessory Building (if any; show location and elevation on site plan)  
-- Must have accessory building design approved also
  - 7. Patio Design
  - 8. Retaining Wall Location and Materials
  - 9. Pool Plans (if any; show location and elevation on site plan)  
-- Must have pool design approved also
  - 10. Portable Toilet Location
- C. Landscape Plans – Submit 30 days prior to final grading
  - 1. Landscape Beds Location and Square Foot Size
  - 2. Plants – Type, Location, Size
  - 3. Trees – Type, Location, Size
  - 4. Landscaping Design around any Mechanical Equipment
  - 5. Retaining Wall – Material Design
  - 6. Court Yard – Material Design

**Plan Exterior Material, Finishes and Color**

List and Include Samples and/or Literature on Each

- A. Masonry products and Color (Brick/Stone/Stucco) \_\_\_\_\_  
\_\_\_\_\_
  - B. Siding Products and Color \_\_\_\_\_  
\_\_\_\_\_
  - C. Soffit/Fascia/Gutter Products and Color \_\_\_\_\_  
\_\_\_\_\_
  - D. Trim Colors \_\_\_\_\_  
\_\_\_\_\_
  - E. Window Colors/Type \* \_\_\_\_\_  
\_\_\_\_\_
- \* Windows that are noticeable from street must be casement, unless exception made by VWDRB*
- F. Roof Product and Color \_\_\_\_\_  
\_\_\_\_\_
  - G. Doors/Type – Front, Garage, Other (Must show detail on plan) \_\_\_\_\_  
\_\_\_\_\_
  - H. Deck Railing (Must show detail on plan) \_\_\_\_\_  
\_\_\_\_\_
  - I. Retaining Wall(s) (Must show detail on plan) \_\_\_\_\_  
\_\_\_\_\_

**Certificate of Insurance**

- A. General Liability
- B. Workers Compensation and Employer’s Liability
- C. Auto

**Liquidated Damages Deposit of \$1,000.00**

**NO WORK MAY BEGIN UNTIL APPROVAL BY THE DESIGN REVIEW BOARD HAS BEEN GRANTED.**

I/we have read the current The Villages at Wicklow Design Guidelines, Covenants, Conditions and Restrictions and fully understand the requirements set forth as they pertain to this application. All work will be completed in conformance with the approved documents and application. Any change to any building associated with this application shall be resubmitted to the Design Review Board and approval obtained prior to commencement of any and all improvements. During construction, I/we agree and will provide gravel to the driveway of this property for use as a temporary access.

Signature: \_\_\_\_\_ Date: \_\_\_\_\_

*Please remember that you must have a contract on the lot before the Design Review Board will accept this submittal.*

**THE LIQUIDATED DAMAGE DEPOSIT OF \$1,000.00 MUST BE INCLUDED WITH THIS APPLICATION. PLEASE MAKE CHECK PAYABLE TO CC LAND PARTNERS, LLC.**

PLEASE NOTE: AN INCOMPLETE SUBMITTAL MAY RESULT IN DELAYS PROCESSING YOUR DESIGN REVIEW APPLICATION. PLEASE BE SURE ALL NECESSARY ITEMS ARE INCLUDED.

*For the use of The Villages at Wicklow Design Review Board only*

Homesite Number: \_\_\_\_\_

Date Received: \_\_\_\_\_

Received By: \_\_\_\_\_

*The Villages at Wicklow Review Board may find it necessary to require additional information upon receipt of this submittal in order to effectively review your plan and move forward with the approval process.*



**The Villages at Wicklow**  
**Property Verification and Inspection – Improvements Completed**

**Property Owner's Name:** \_\_\_\_\_  
**Current Mailing Address:** \_\_\_\_\_

**Telephone Numbers:** Business/Day (\_\_\_\_) \_\_\_\_\_  
Residence/Evening (\_\_\_\_) \_\_\_\_\_  
Mobile (\_\_\_\_) \_\_\_\_\_

Homesite number: \_\_\_\_\_ Phase: \_\_\_\_\_  
Homesite Address: \_\_\_\_\_

The Villages at Wicklow Design Review Board has completed the property verification and inspection of the above address after all improvements to Property have been made according to the requirements set forth in The Villages at Wicklow Guidelines and Declaration of Restrictions as they pertain to property damage to existing community elements. This inspection is **NOT** intended to be a notice of final approval of the improvements or noncompliance of such improvements, but to verify that the present condition of the community elements that existed prior to construction are in the same condition or have been repaired to the satisfaction of the VWDRB. By signing below, I/we agree with the conclusion of the Property inspection of the VWDRB and have read and understand the comments, if any, noted below pertaining to this conclusion.

**Property Verification – Existing Elements**

- A. Pins are Located (Property Boundary Lines)
- B. Damage to Property/Amenities
  - 1. Sidewalk/Curbs
  - 2. Utility boxes, etc.
- C. Landscape/Drainage Conforms to Plans Submitted

Comments: \_\_\_\_\_  
\_\_\_\_\_

Signature: \_\_\_\_\_ Date: \_\_\_\_\_  
Property Owner(s)

Signature: \_\_\_\_\_ Date: \_\_\_\_\_  
The Villages at Wicklow Design Review Board Representative

In order to avoid mistakes or issues that will slow the approval process, please note the following:

1. As mentioned, plans must show all sides of the elevation, with *all exterior products drawn in*.

*Example:*

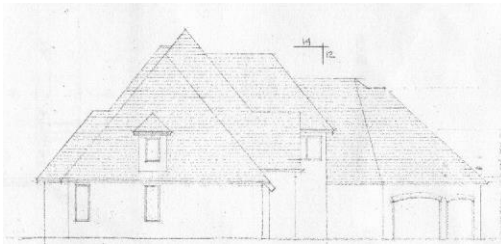

*Not acceptable*

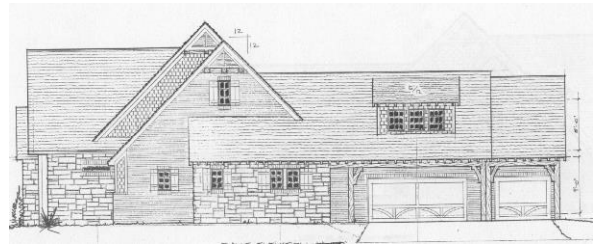

*Acceptable*

2. Please make sure that you have included a site plan *drawn to scale* that clearly shows the house as it will sit on the lot, with all easements and setbacks plainly noted. See checklist for additional items that must be called out on the site plan.
3. The Design Review Board will be looking specifically at the front elevation for the following features:
  - Dimension
  - A variety of exterior products to create an aesthetically pleasing façade
  - Balance/consistency in design & products used

It is not the intention of the Design Review Board to encourage or promote a “cookie-cutter” style subdivision; rather, it is our goal to encourage unique designs that complement the premise and style of The Villages at Wicklow. When a person drives through Wicklow, he or she should be able to easily see that while each home offers it’s own individual design, the common theme flows seamlessly throughout the neighborhood.